

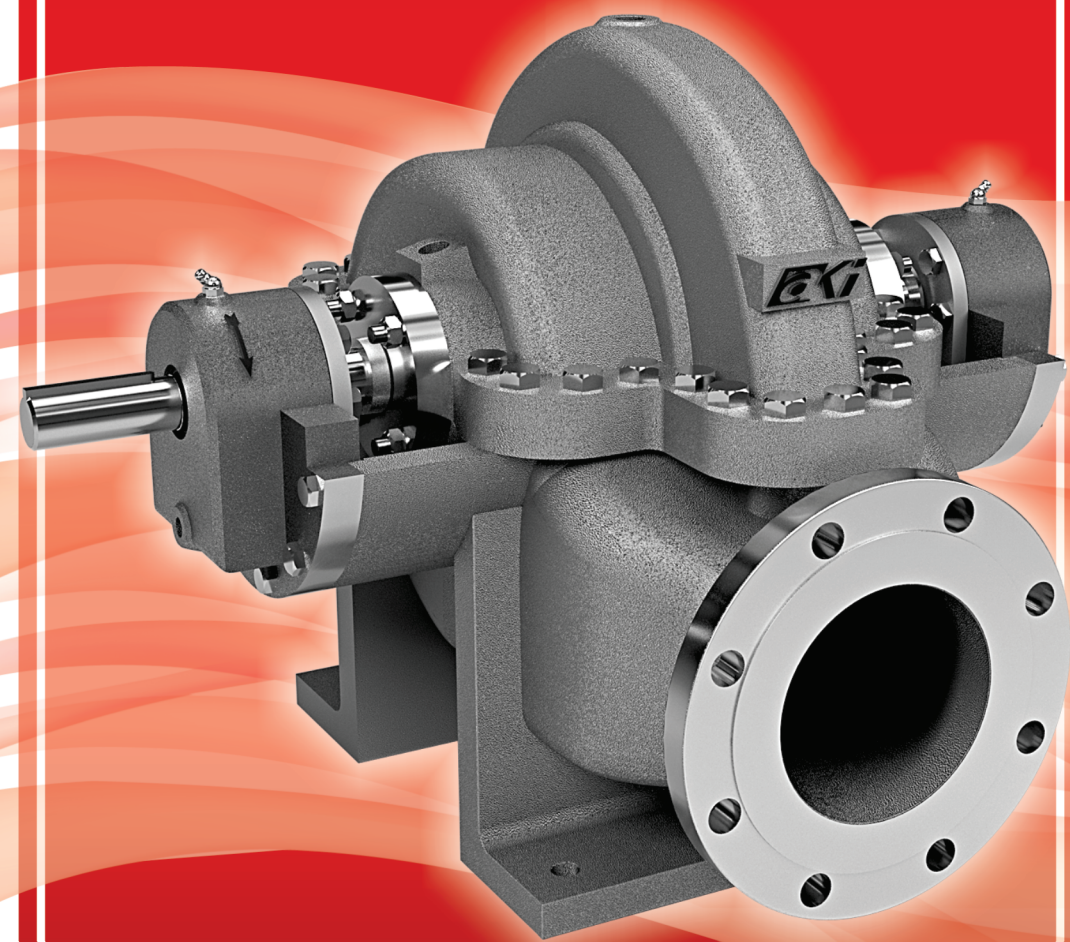

chemflo[®]



**TYPE DSP
DOUBLE SUCTION PUMPS**

BTM is an associate company of Akay Industries Pvt Ltd



**TYPE DSP
DOUBLE SUCTION PUMP**

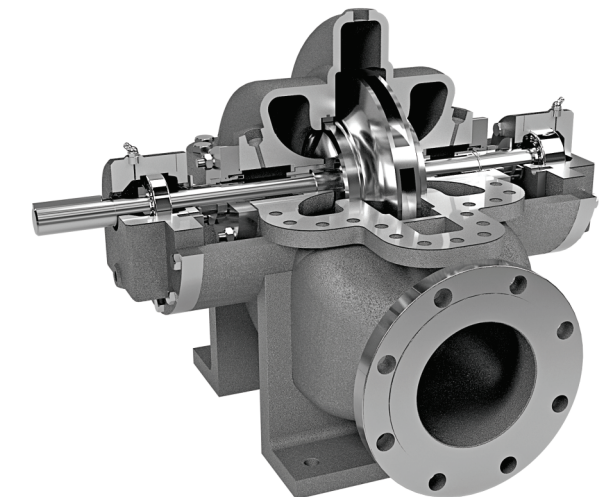
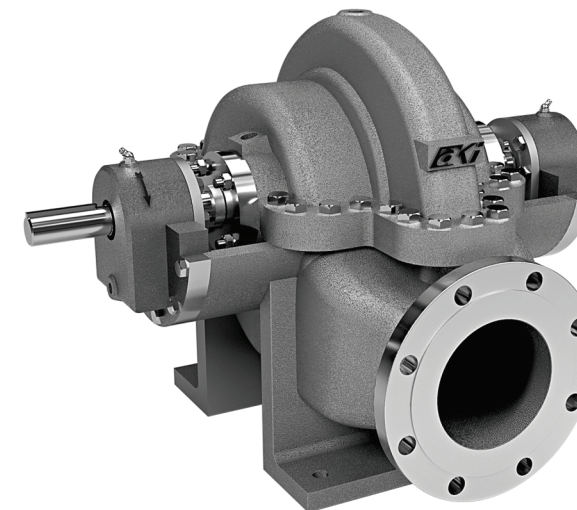

HYDRAULIC COVERAGE

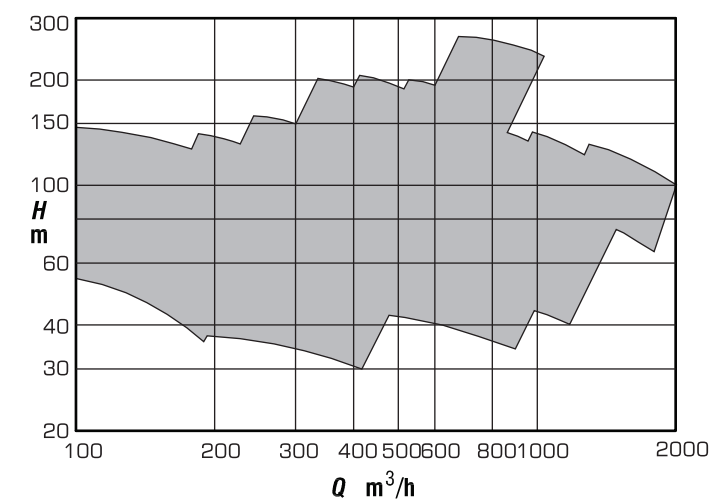

RANGE

- Capacity to 2000³ m /h
- Head to 280 m
- Temperature to 200°C
- Pressure to 5000 kPa

FEATURES

- Double volute casing design balances radial thrust and there by minimises shaft deflection .
- Double suction impeller design with adequate suction chamber area give rise to low NPSH.
- Axial split design allows the removal of rotor without disturbing driver, suction & discharge piping.
- Seal chamber accommodates all types of sealing arrangement of chemflo mechanical seal.
- Double suction impeller balances axial thrust and hence increases bearing life.
- Maximum shaft deflection less than 0.05 mm at face of the stuffing box ensures long seal and bearing life and low maintenance.

SERVICES

- **Process -**
Quench water, Stripper bottoms
Reboiler circulation, Cooling tower
Evaporator, Condensate
- **General -**
River water, Brine, Sea water



BTM PROCESS CONTROLS PVT LTD.

Address: Plot No 162/A&162/B Gamanagatti Industrial Estate
Hubballi Karnataka 580024 | Tel: +91 (0) 836-2486001/02
Email: business@btmprocesscontrols.com
Web: www.btmprocesscontrols.com

